



DOSATRON®

WATER POWERED DOSING TECHNOLOGY

SCHEMATICS

Dosatron Liquid Dispenser **Model # D8R – 40 GPM**

1:500 – 1:50

2 – 110 PSI

Suggested Installation:

200 mesh/80 micron water filter prior to unit

One-way check valve downstream from unit for water hammer protection

Suggested Maintenance Interval:

Replace injection seals every 12 months

Replace Maintenance Kit components every 3 to 4 years

(Kit references available on Page 1)

DOSATRON SALES & SERVICE - NORTH & CENTRAL AMERICA

Dosatron International, Inc.

Phone: 727-443-5404 Service: (800) 523-8499

Fax: 727-447-0591

www.dosatronUSA.com

D8R
11/03

40 GPM - 1:500 - 1:50
2.2 - 116 psi

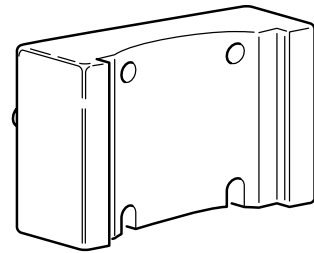
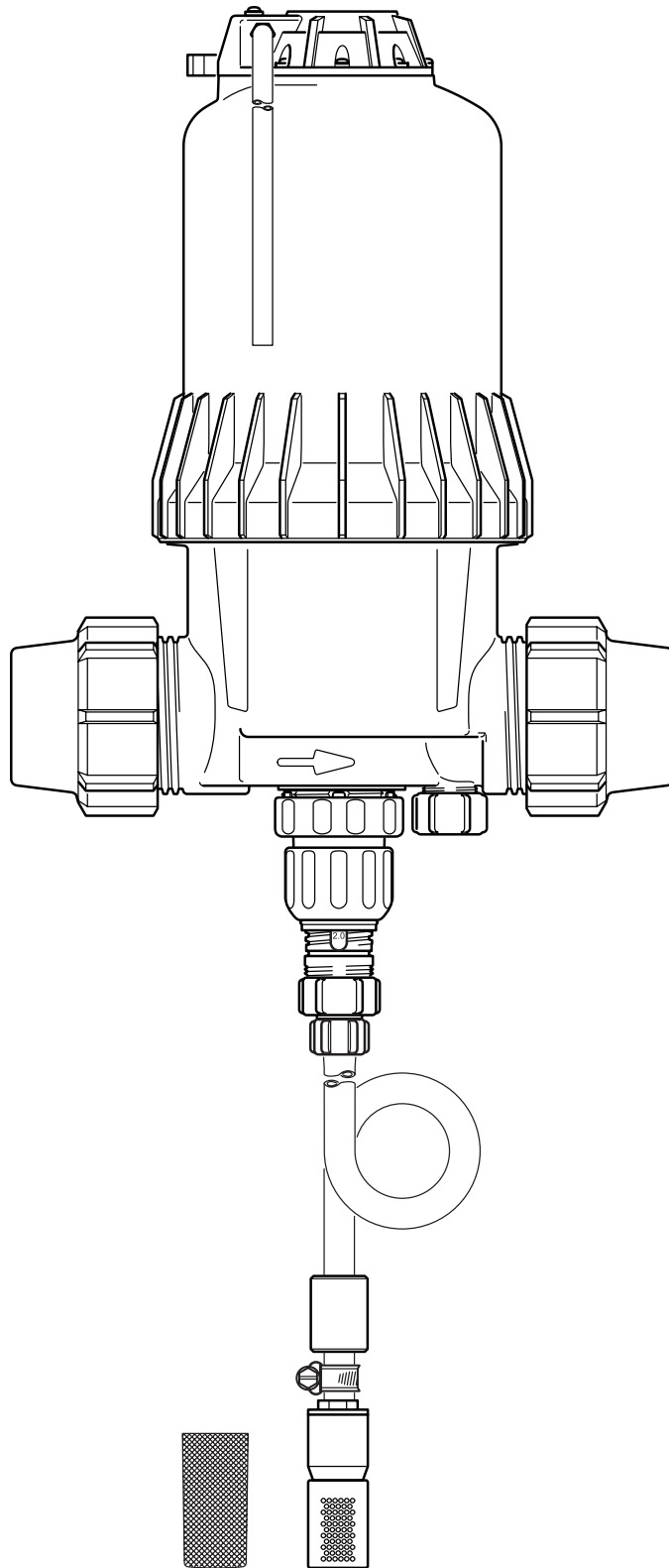

8ED005 - Injection Seal Kit
8EM001 - Motor Seal Kit

D8R
11/03

40 GPM - 1:500 - 1:50
2.2 - 116 psi

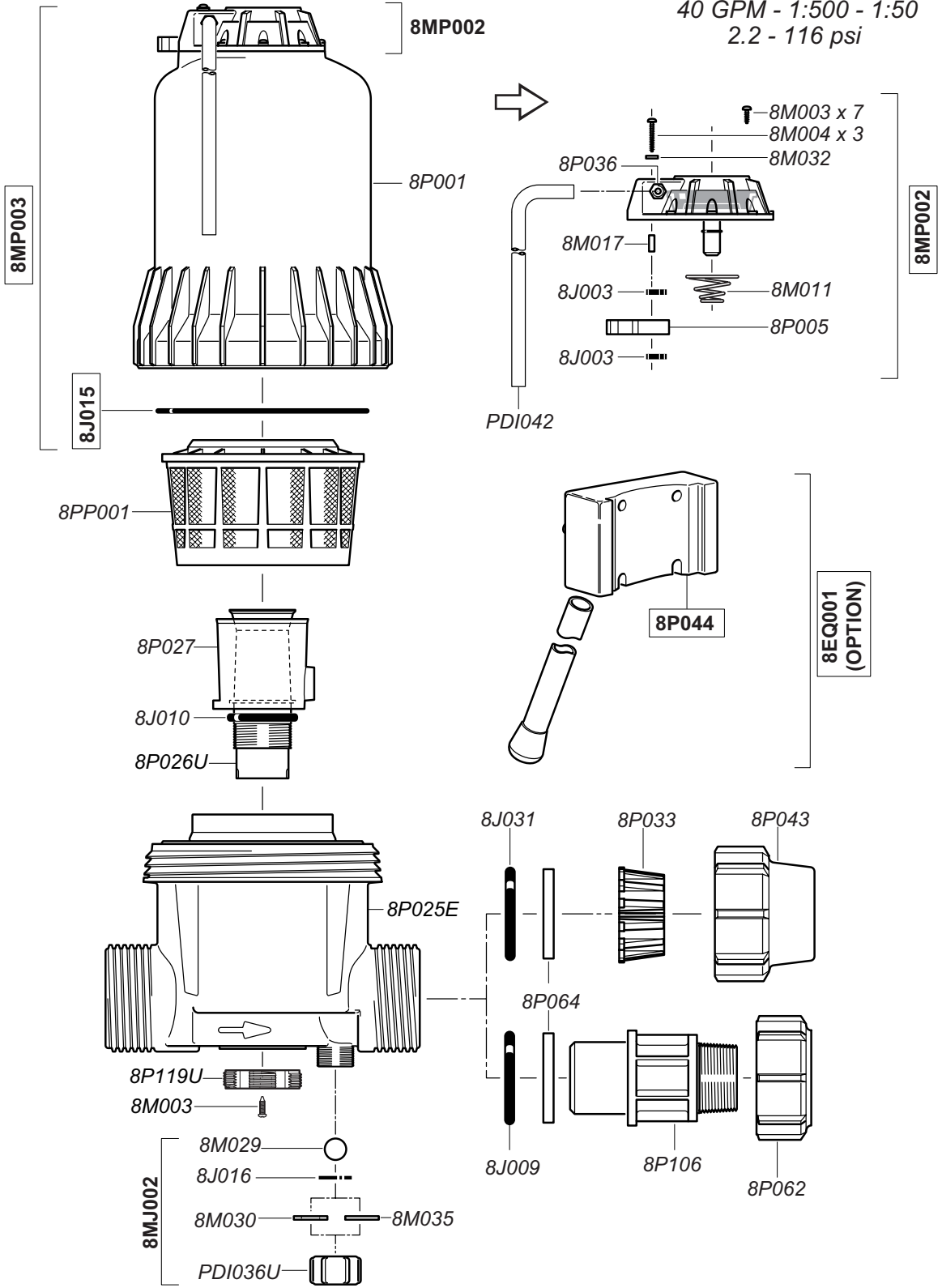

D8R

40 GPM - 1:500 - 1:50
2.2 - 116 psi

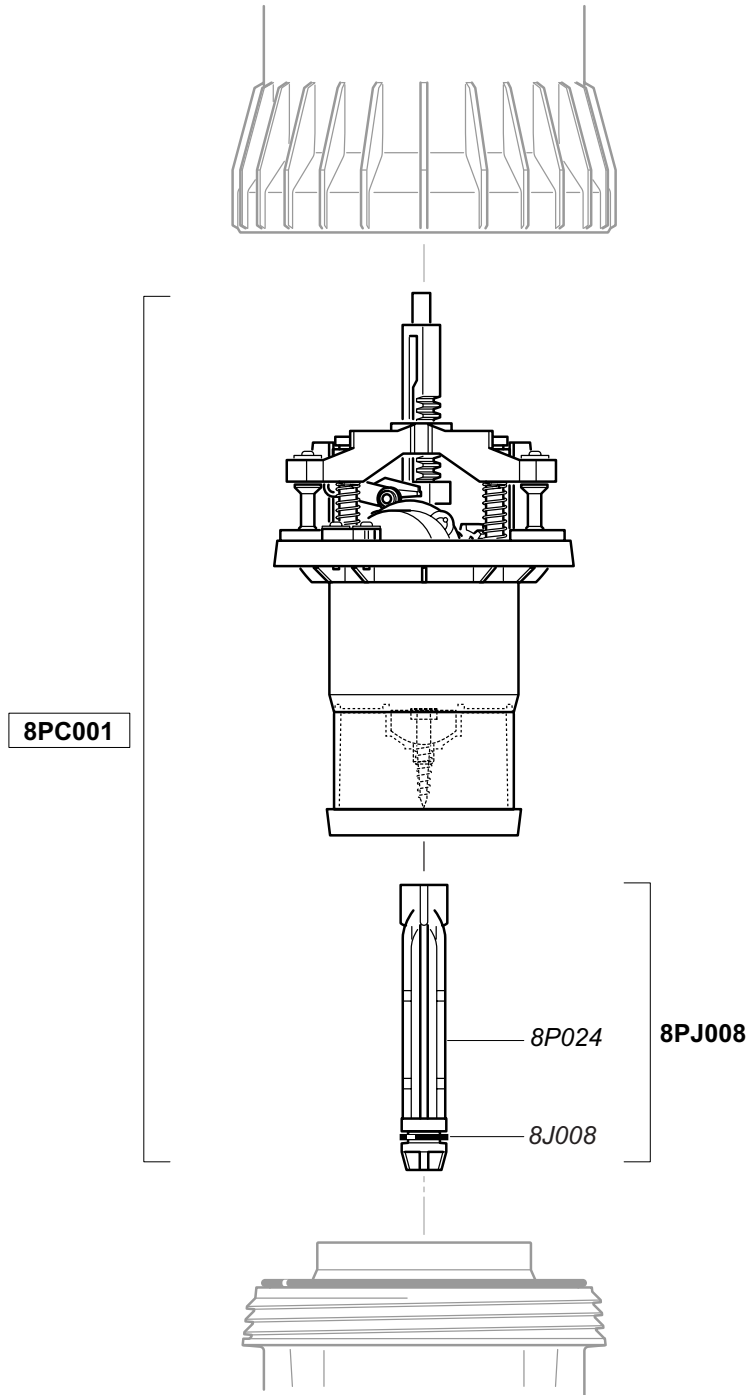

D8R
11/03

40 GPM - 1:500 - 1:50
2.2 - 116 psi

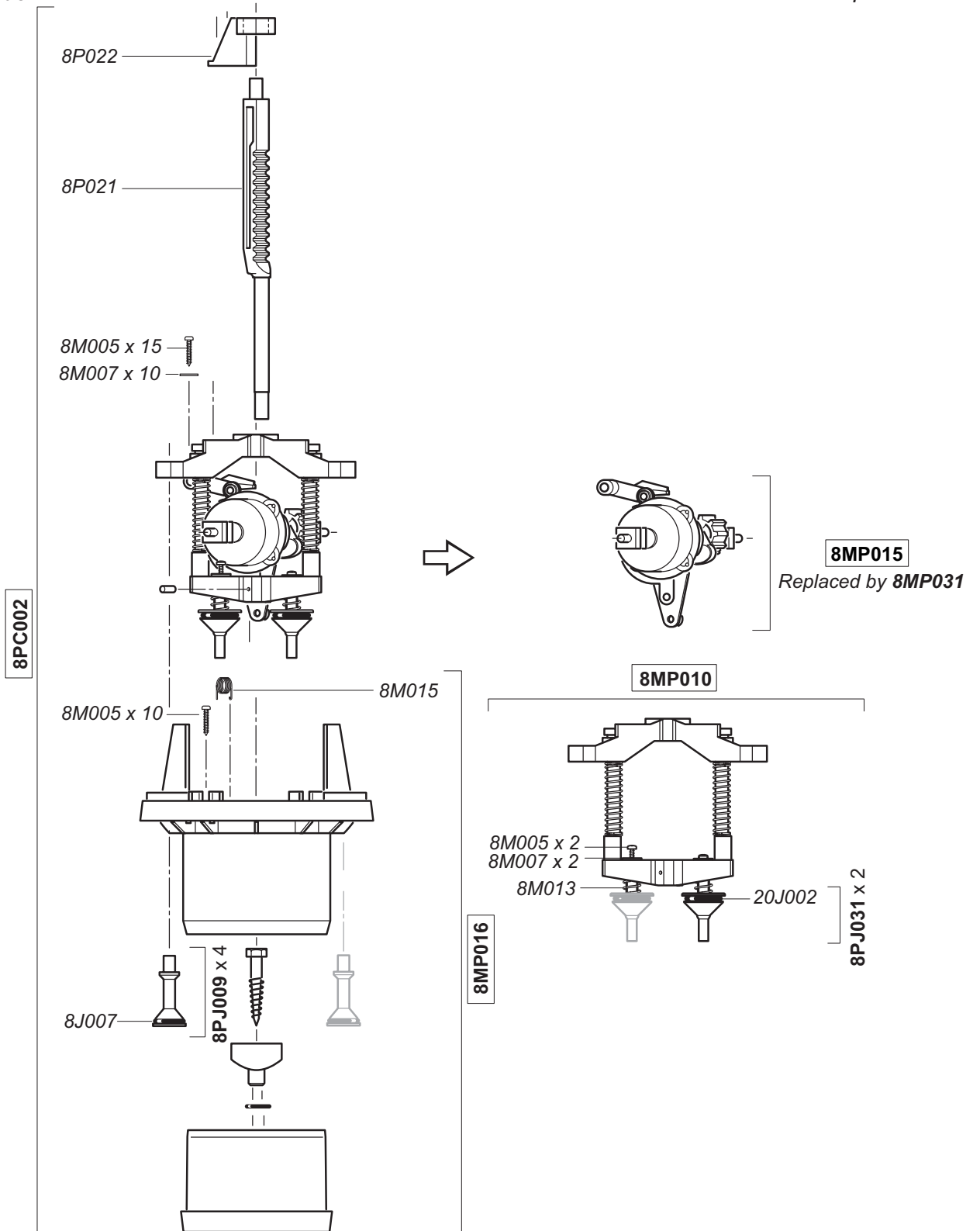

D8R
11/03

40 GPM - 1:500 - 1:50
2.2 - 116 psi

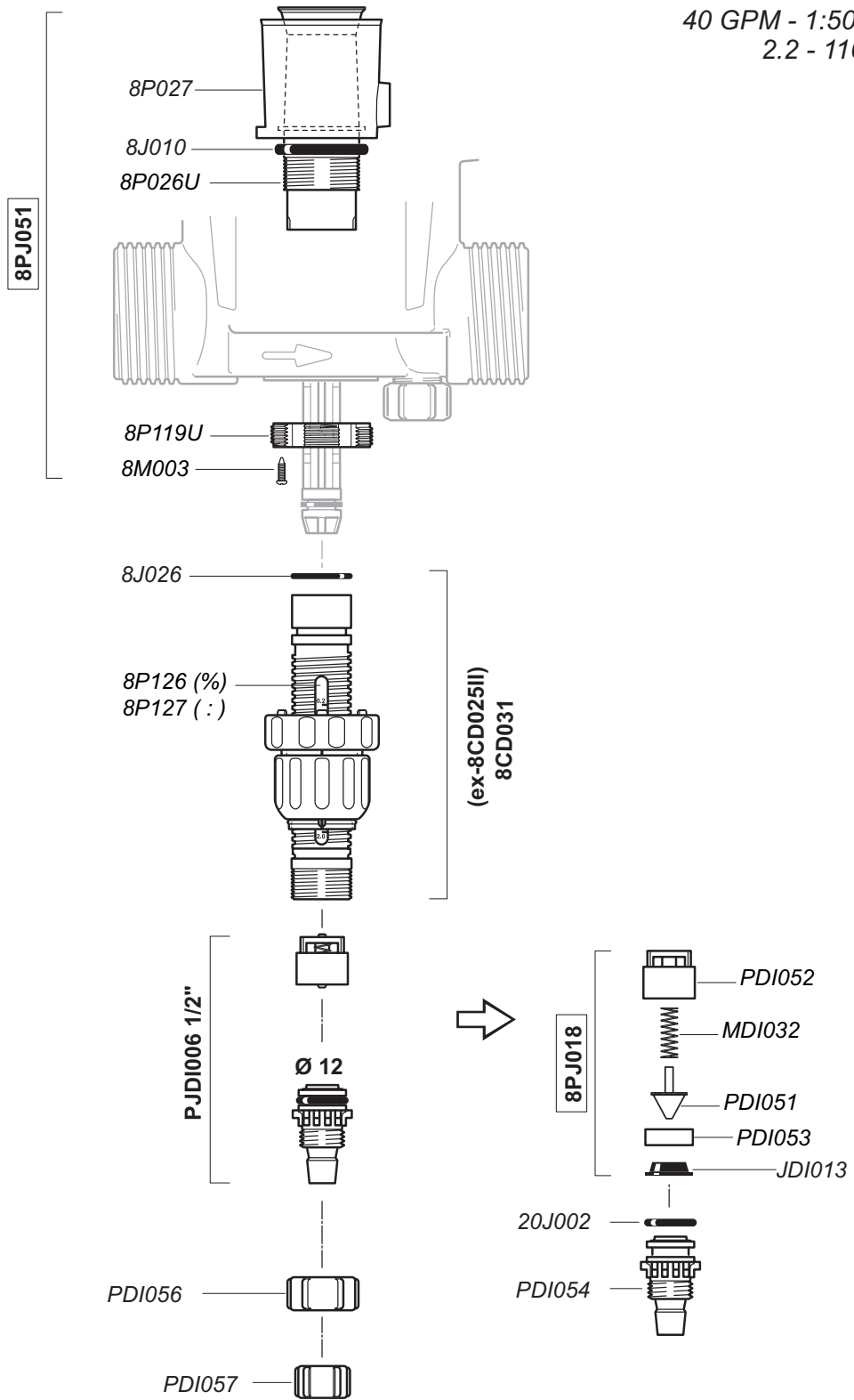

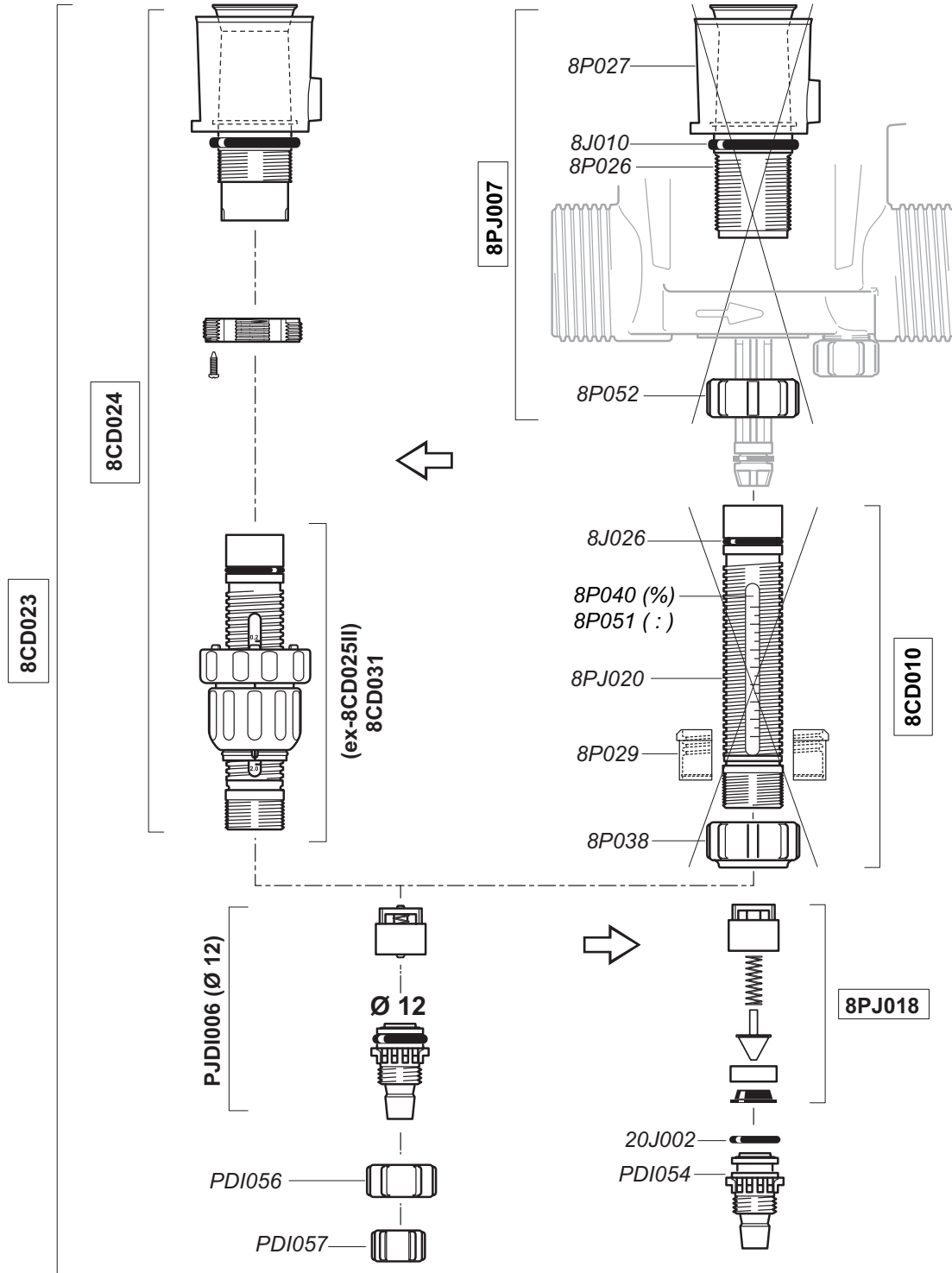

D8R
11/03

40 GPM - 1:500 - 1:50
2.2 - 116 psi

